

Foundations

Greenhouse Foundation

This kitset greenhouse is designed to be attached to a well built raised wall. You can choose any material you like (i.e. brick, block, concrete, stone, etc...) but please ensure it is structurally sound, level, square and the critical dimensions (as listed below) are adhered to. If you do not have experience in constructing a wall yourself, or are unsure please contact a local professional tradesperson for guidance.

Important information

When building this greenhouse base/foundation wall there are 4 critical dimensions that must be adhered to for the greenhouse base to attach correctly. These dimensions are

1. Internal Width. **3140mm**
2. Internal Length. **3764mm**
3. Doorway width. **1250mm**
4. Wall height (from top of slab to top of wall). **600mm**

There are 3 main components to this greenhouse base/foundation wall.

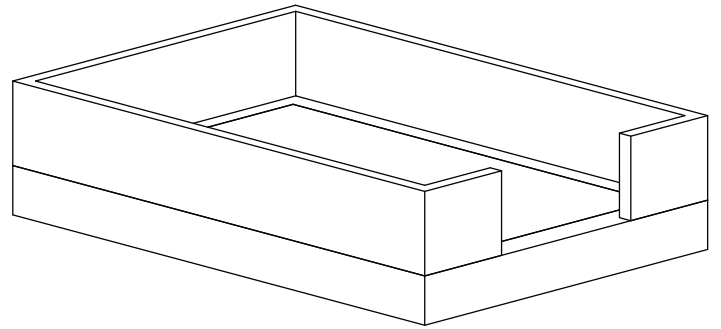

Footing

The concrete footing should be poured to a depth of at least 350mm and have steel rebar through-out.

Wall

This can be constructed from concrete block, brick, stone or whatever you prefer. The thickness of the wall can vary, but must move outwards so it does not effect the critical dimensions (internal width, Internal length). Please ensure the wall is built level and square with a flat surface on the top of the wall for the box section aluminium greenhouse base to sit upon and attach to. The wall should be structurally sound and we recommend tying the wall to the footing with steel reinforcing bar.

Slab

The slab is usually poured last. This should be 100mm thick, preferably with steel mesh, and ties to the footings. Use hardfill underneath.

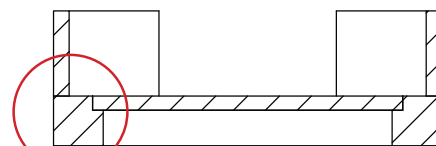
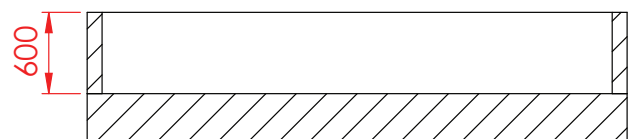
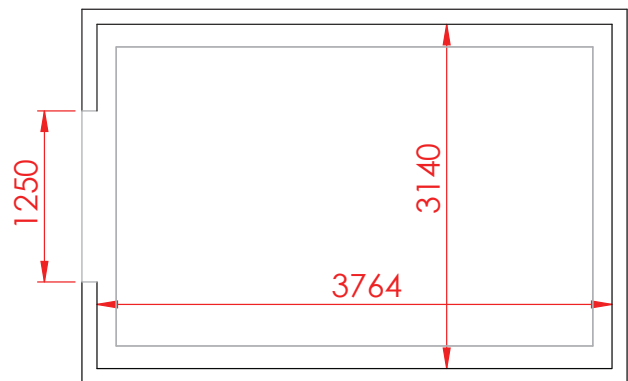

Notes:

- Critical dimensions (in RED) must be adhered to. Variable dimensions (in BLACK) can and will change depending on your wall type (concrete block, stone, brick) and the soil and site conditions.
- Concrete strength to be 20Mpa after 28-days.
- Where hardfill exceeds 150mm depth, compact in layers of 150mm.
- Use steel re-bar through-out.
- Tie slab to footing with steel ties
- Consider drainage/power/water for inside of Greenhouse
- Bottom of footing must be below the frost line
- Footings/piles dimensions should be adjusted to suit soil and site specific conditions.
- If in doubt ask.

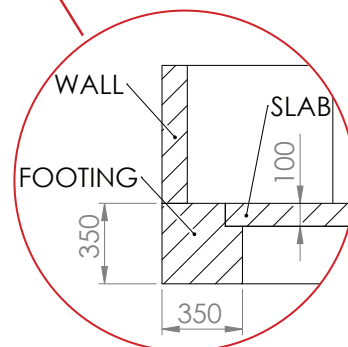

Base assembly

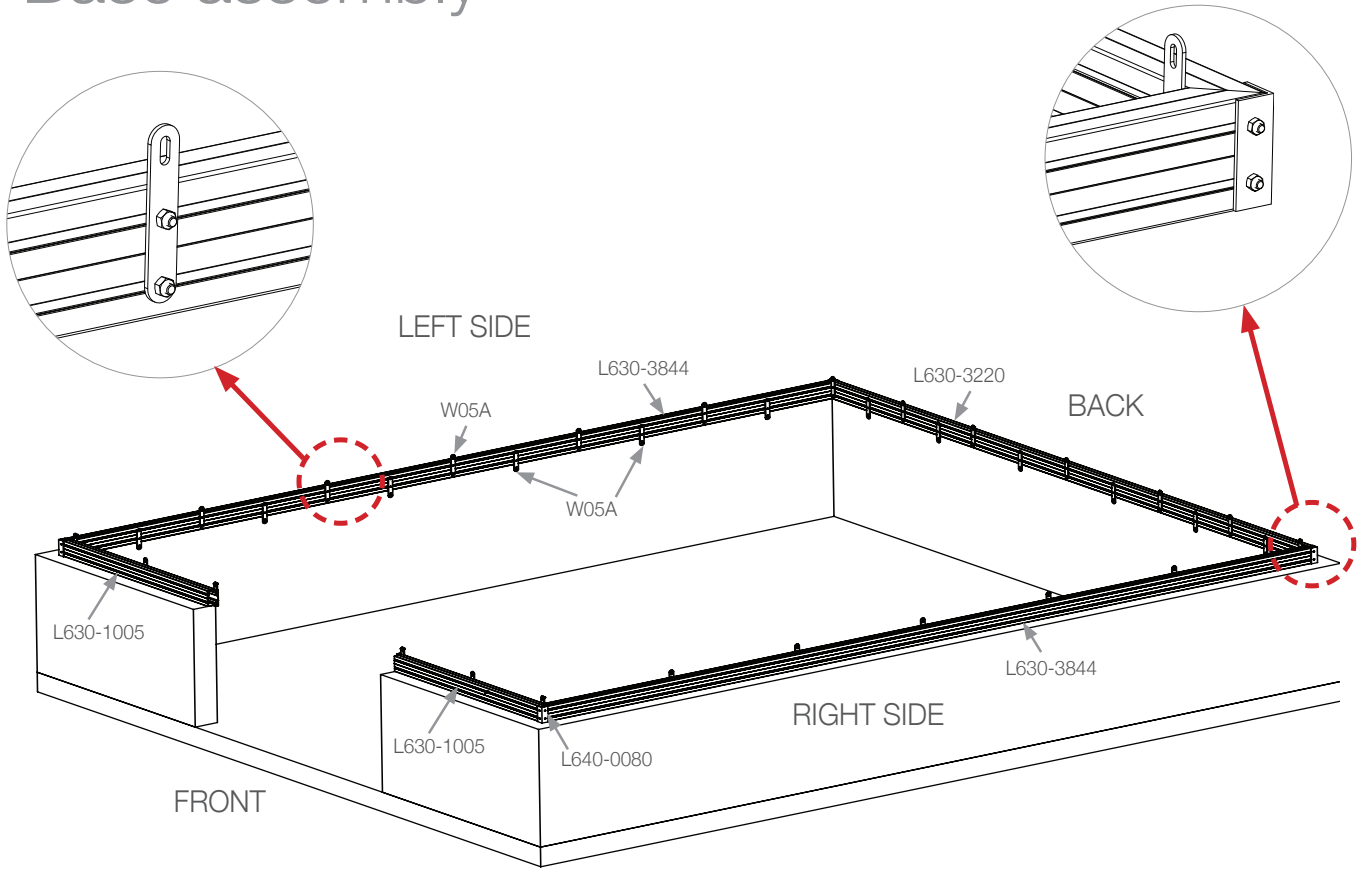

PARTS LIST

You will need:

- 2x L630-3844
- 2x L630-1005 (Short front base)
- 1x L630-3220
- 4x L640-0080 (Corner stakes)
- 45x W05A (Brackets)
- 106x M01 (Nuts)
- 106x S03 (Bolts)
- 13m FS40 (40mm foam strip)

Step 1.

Layout base components as per diagram below

